

HOW IT WORKS

The following scheme below represents a lubrication cycle through the standard progressive sequence at the outlets **8 - 1 - 3 - 5 - 7**.

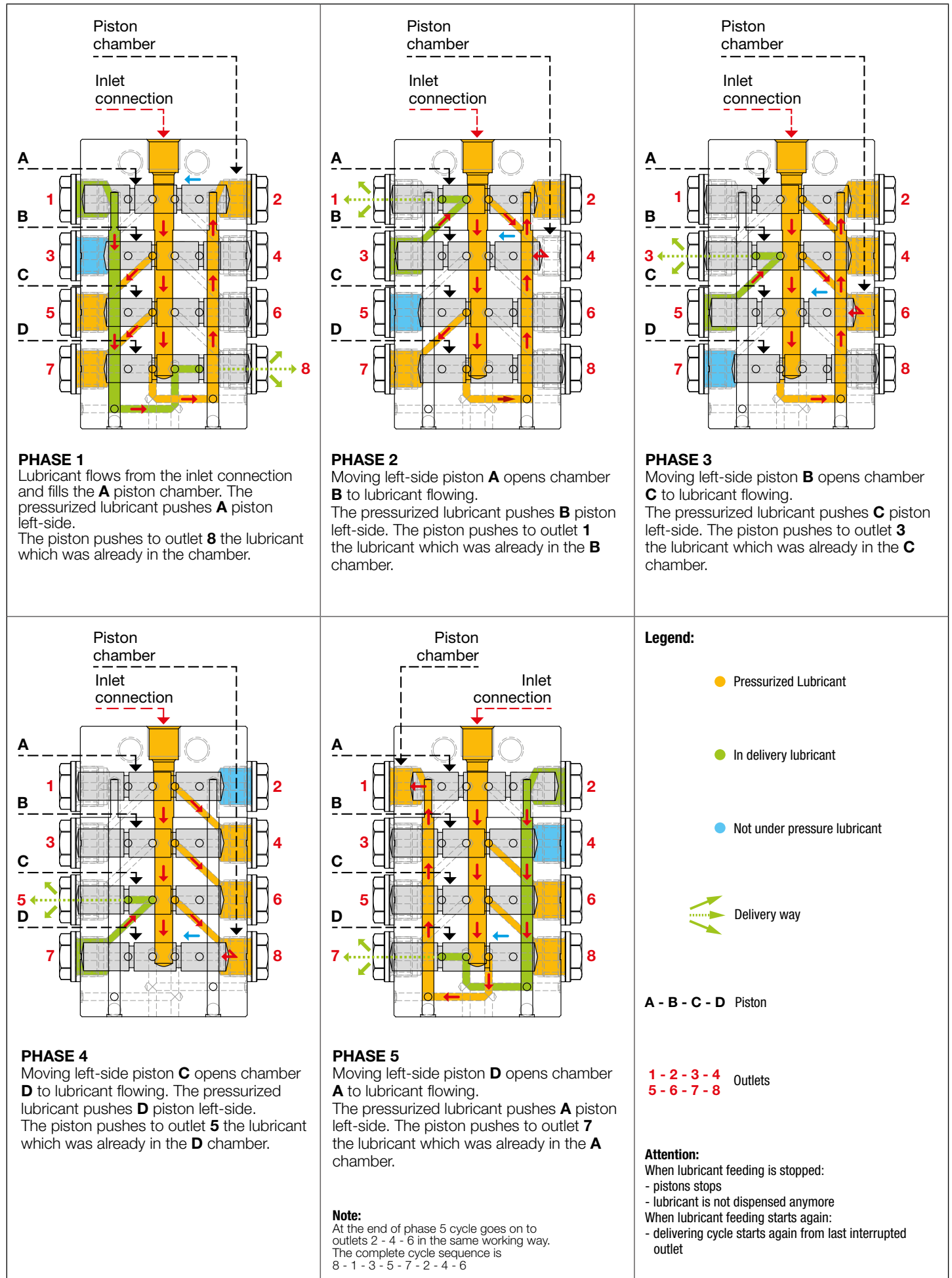

OUTLETS AND FLOW RATES

Lubricant outlets are side placed and can work independently or bined. Flow rate may be set by adjusting screws from 0,025 - 0,050 - 0,075 cm³/cycle for MDV-M distributors model to 0,1 - 0,2 - 0,4 cm³/cycle for MDV-L distributors.

DELIVERY EXAMPLE

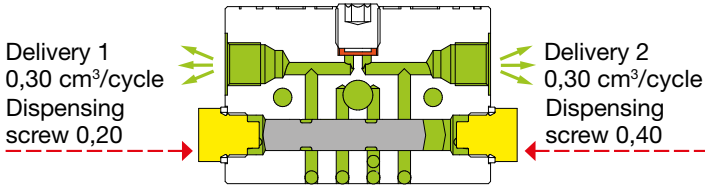

Total lubricant flow rate is equal to the sum of the flow rate indicated on each adjusting screw ($0,20 + 0,40 = 0,60$), divided by 2 ($0,60/2=0,30$ cm³/cycle).

LUBRICANT PATH

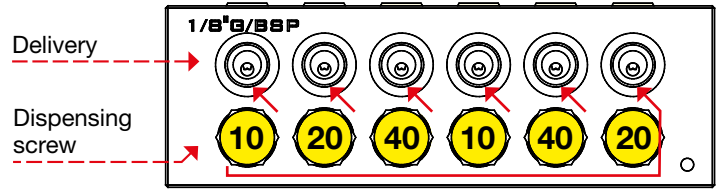

This picture shows lubricant path depending on each adjusting screw's flow rate. Dispensing sequence is represented on top side of the divider (see example in **Bypass elements** section).

SINGLE OR DOUBLE DELIVERY

Each section of the device can dispense lubricant through a single or double delivery. This is possible thanks to the screw plug's pin orientation, which is placed onto the frontal side of the divider.

SINGLE DELIVERY

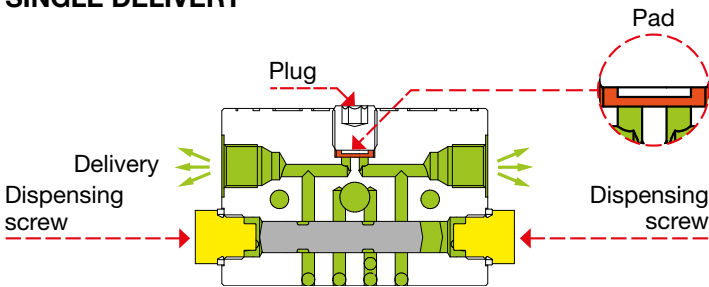

If the mechanical device (tablet supplied with the dispenser) is positioned with the hollow part facing upwards, lubricant dispensing takes place from one side to the other progressively.

DOUBLE DELIVERY

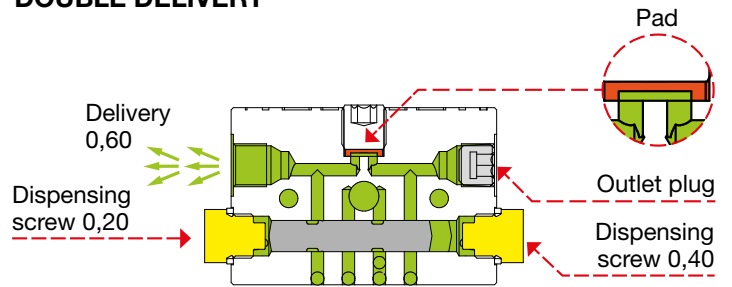

If the hollow part of the pad (supplied with the distributor) is facing downwards, lubricant dispensing takes place simultaneously in both sections. By positioning the outlet cap on the opposite delivery, will result a delivery with flow rate equal to the sum of the individual flow rates ($0,20 + 0,40 = 0,60$).

BYPASS ELEMENTS

Using a hollow screws bypass element, different flow rates may be available for each outlet (single, double, triple etc.)

DOUBLE DELIVERY

Delivery $0,20 + 0,20 = 0,40$

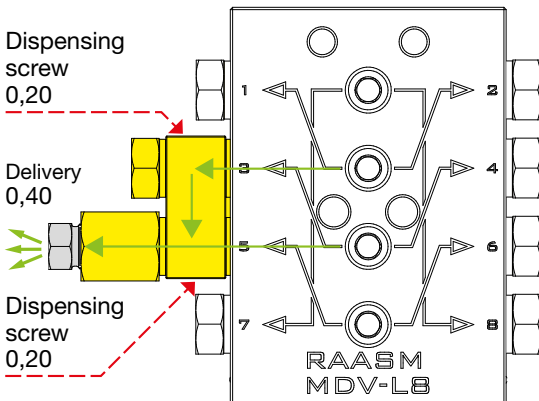

TRIPLE DELIVERY

Delivery $0,20 + 0,20 + 0,20 = 0,60$

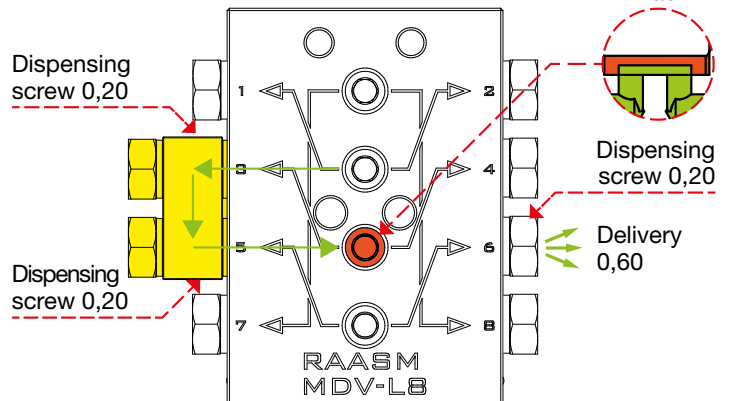

Overall dimensions (mm)

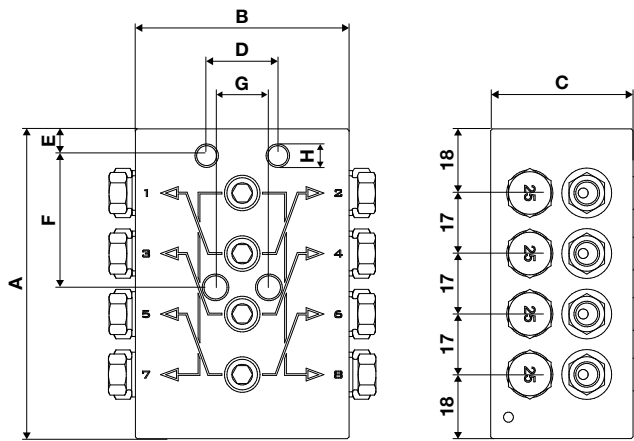

Abbr.	A	B	C	D	E	F	G	H
MDV-M6	70	40	30	20	5,5	38	12	ø 5,5
MDV-M8	88	40	30	20	5,5	38	12	ø 5,5
MDV-M10	104	40	30	20	5,5	38	12	ø 5,5
MDV-M12	122	40	30	20	5,5	38	12	ø 5,5
MDV-M14	138	40	30	20	5,5	38	12	ø 5,5

Abbr.	A	B	C	D	E	F	G	H
MDV-L6	70	60	40	20	7,5	37	15	ø 5,5
MDV-L8	88	60	40	20	7,5	37	15	ø 5,5
MDV-L10	104	60	40	20	7,5	37	15	ø 5,5
MDV-L12	122	60	40	20	7,5	37	15	ø 5,5
MDV-L14	138	60	40	20	7,5	37	15	ø 5,5

ACCESSORIES MDV-M and MDV-L

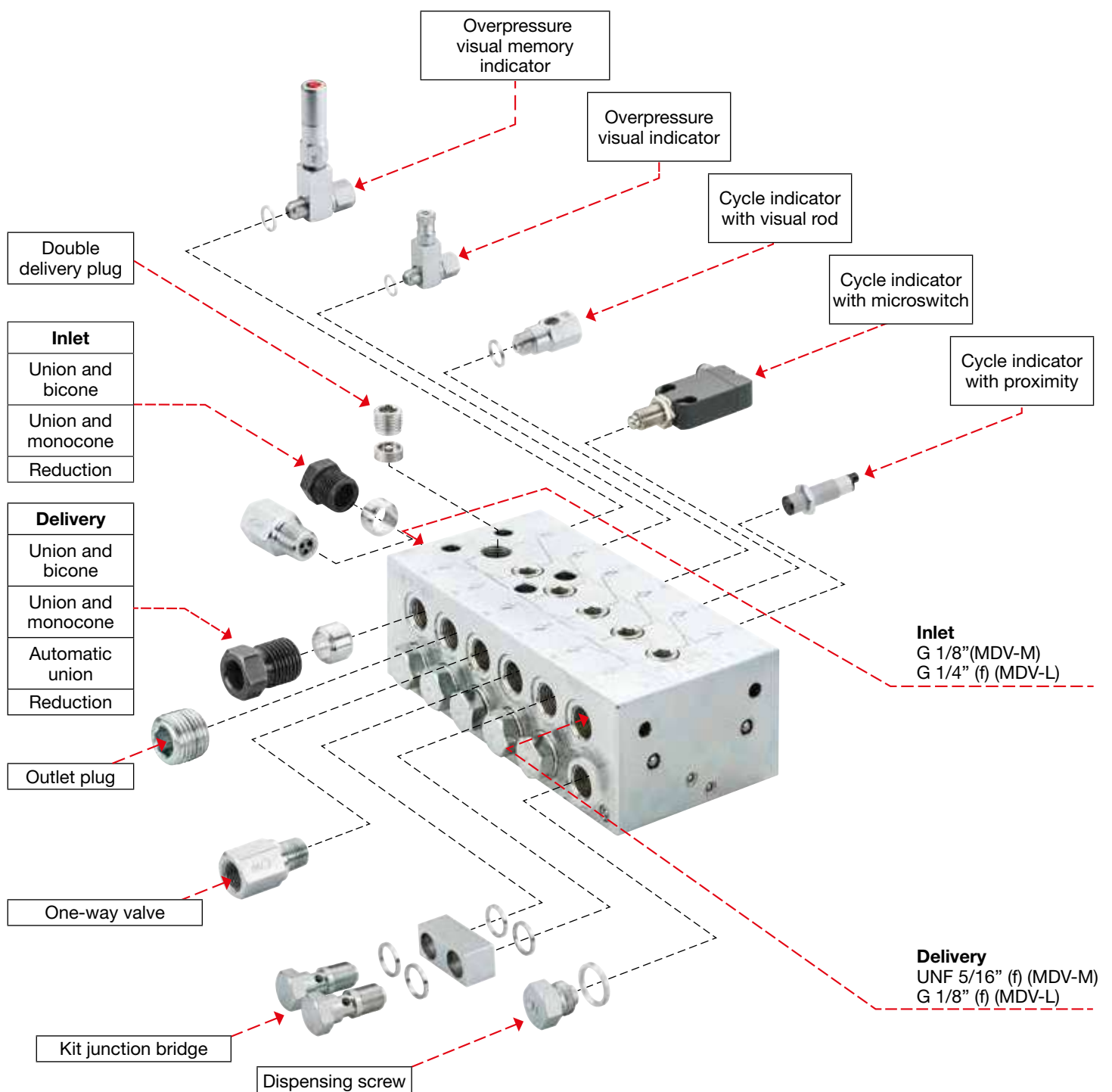

DISPENSING SCREW

	Distributors	P/N	Flow rate (cm ³ /cycle)	Connection	Dispensing screw Abbr.
	MDV-M	3081650	0,025	M7 x 1	25
		3081651	0,050	M7 x 1	50
		3081652	0,075	M7 x 1	75
	MDV-L	3081600	0,100	M10 x 1	10
		3081601	0,200	M10 x 1	20
3081602		0,400	M10 x 1	40	

OUTLET PLUG

	Distributors	P/N	Delivery connection
	MDV-M	3200091	UNF 5/16" (m)
	MDV-L	3200095	G 1/8" (m)

ONE-WAY VALVE

	Distributors	P/N	Delivery connection	Inlet connection
	MDV-M	3200081	UNF 5/16" (m) - outlet UNF 5/16" (f)	-
		3200082	UNF 5/16" (m) - outlet G 1/8" (f)	-
		3200085	-	G 1/8" (m) - outlet G 1/8" (f)
		3200087	-	G 1/8" (m) - outlet G 1/4" (f)
	MDV-L	3200083	G 1/8" (m) - outlet G 1/8" (f)	-
3200084		G 1/8" (m) - outlet G 1/4" (f)	-	
3200086		-	G 1/4" (m) - outlet G 1/4" (f)	

BYPASS ELEMENT KIT (without outlet)

	Distributors	P/N	Connection
	MDV-M	3080050	UNF 5/16" (m)
	MDV-L	3080070	G 1/8" (m)

BYPASS ELEMENT KIT (with outlet)

	Distributors	P/N	Connection
	MDV-M	3080051	UNF 5/16" (m) - outlet UNF 5/16" (f)
		3080052	UNF 5/16" (m) - outlet G 1/8" (f)
	MDV-L	3080071	G 1/8" (m) - outlet G 1/8" (f)
		3080072	G 1/8" (m) - outlet G 1/4" (f)

OVERPRESSURE VISUAL MEMORY INDICATOR

This indicator has a coloured rod that raises and remains in position when there is an abnormal pressure rise in the system. This allows to locate the discharge involved.

	UNF 5/16" (m) outlet UNF 5/16" (f)		UNF 5/16" (m) outlet G 1/8" (f)		G 1/8" (m) outlet G 1/8" (f)		G 1/8" (m) outlet G 1/4" (f)		Pressure
	Distributors	P/N	Distributors	P/N	Distributors	P/N	Distributors	P/N	
	MDV-M	3081542	MDV-M	3081552	MDV-L	3081562	MDV-L	3081572	100 bar
		3081543		3081553		3081563		3081573	150 bar
		3081544		3081554		3081564		3081574	200 bar
		3081545		3081555		3081565		3081575	250 bar

OVERPRESSURE VISUAL INDICATOR

This indicator has a rod that is raised when it reaches the set pressure and falls when the pressure falls below this value.

	UNF 5/16" (m) outlet UNF 5/16" (f)		UNF 5/16" (m) outlet G 1/8" (f)		G 1/8" (m) outlet G 1/8" (f)		G 1/8" (m) outlet G 1/4" (f)		Pressure
	Distributors	P/N	Distributors	P/N	Distributors	P/N	Distributors	P/N	
	MDV-M	3081582	MDV-M	3081589	MDV-L	3081596	MDV-L	3081535	
3081583		3081590		3081597		3081536		150 bar	
3081584		3081591		3081598		3081537		200 bar	
3081585		3081592		3081599		3081538		250 bar	

Attention: overpressure indicators have to be installed on lubricant outlets which need to be checked.

MICROSWITCH CABLE

	Distributors	P/N	Description	Cable length
	MDV-M MDV-L	3081524 3081525	With connector cable M12 - 5 poles With connector cable M12 - 5 poles	5 m 10 m

CYCLE INDICATOR

Three different cycle indicators may be installed on distributor to check system status:

Visual rod indicator type A. Provided with female thread M12X1 for the connection with microswitch indicator (P/N 3081480). Proximity (P/N 3081490).

(A) 	Distributors	Dispensing screw	
		P/N (A)*	Flow rate (cm ³ /cycle)
	MDV-M	3081401	0,025
	MDV-M	3081402	0,050
	MDV-M	3081403	0,075
	MDV-L	3081421	0,100
	MDV-L	3081422	0,200
	MDV-L	3081423	0,400

Visual rod indicator type B (on request). Provided with a rod directly connected to divider's piston. The 1 rod comes out when the piston is working.

(B) 	Distributors	Dispensing screw	
		P/N (B)*	Flow rate (cm ³ /cycle)
	MDV-M	3081404	0,025
	MDV-M	3081405	0,050
	MDV-M	3081406	0,075
	MDV-L	3081424	0,100
	MDV-L	3081425	0,200
	MDV-L	3081426	0,400

Microswitch indicator * The rod of the visual indicator type A is directly connected to divider's piston and it activates a microswitch which produces an electrical signal each working cycle.

	Distributors		P/N
	MDV-M	MDV-L	3081480

"Proximity" sensor indicator * A "proximity" capacity sensor detects if the rod of the visual indicator type A connected to divider's piston is working and it produces an electrical signal each working cycle.

	Distributors		P/N
	MDV-M	MDV-L	3081490

* Cable for microswitch and "proximity" non included (sold separately).

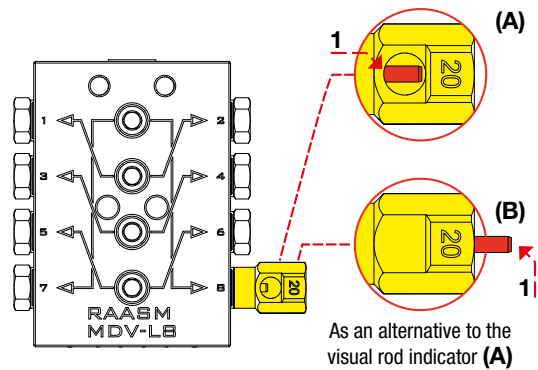

Attention:

The microswitch indicator and/or proximity sensor can only be supplied if combined with type A rod indicator.

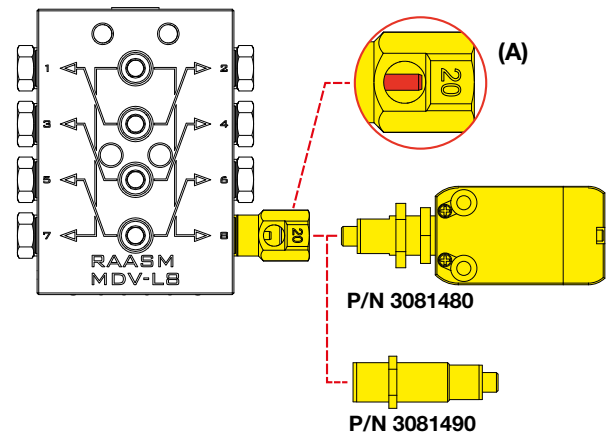

*** Attention:**

The cycle indicators are installed in the standard version in correspondence of the pumping piston placed at the outlet of the distributor (bottom right). For non-standard installation please call the technical department.